

SPECIFICATION	VALUE
NO. of PHASES	3
NO. of POLES	8
RATED VOLTAGE(V)	24
RATED CURRENT(A)	1.9±10%
RATED POWER(W)	26
RATED SPEED(RPM)	4000±10%
RATED TORQUE(mN.m)	63
PEAK CURRENT(A)	5.7
PEAK TORQUE(mN.m)	180
SENSOR	HALL SENSOR
INSULATION CLASS	CLASS B
INSULATION RESISTANCE	100MΩ MIN @ 500VDC
DIELECTRIC STRENGTH TEST	500VAC for 1 MINUTE
BEARING TYPE	NMB BALL BERRING, C3

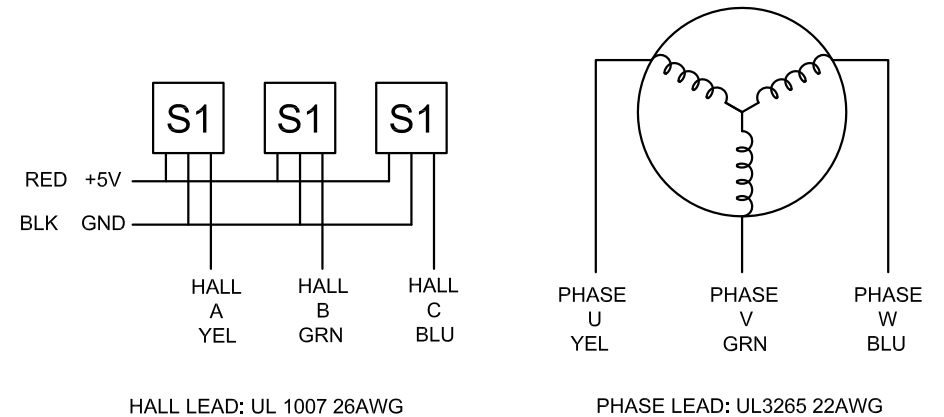

	APVD		
	CHKD		
1.5:1	DRN		
SCALE	SIGNATURE	DATE	

BRUSHLESS DC MOTOR

42BLS47-24-01